



EX



CNC LATHE 3579 SERIES



TAKISAWA[®]
T A I W A N

TAIWAN TAKISAWA TECHNOLOGY CO., LTD.

No.505, Sec-3 Yeng-ping Road, Ping Chen City, Taoyuan Hsien, Taiwan.

Tel: 886-3-4643166

Fax: 886-3-4643674

E-mail: bryan@takisawa.com.tw

Web site: www.takisawa.com.tw



Built-in Spindle

Built-in power motor and accurate spindle

- Built-in and direct-drive spindle motor for powerful cutting.
- Hide-in coolant in spindle for stability.
- Indexing can be 0.001 degree for accurate.



Spindle Oil Cooler



X Axis Live Tool Holder



Z Axis Live Tool Holder



Disc brake orientation system

- Orientating in very degree.
- The C axis won't be affected when it is lucked.
- Enhance the orientation rigidity and avoid vibration while drilling.

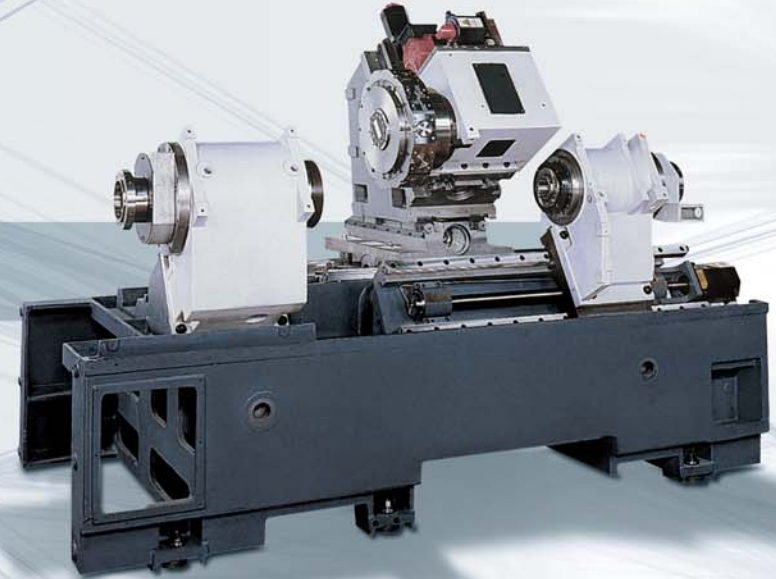

X Axis Power Tooling



Z Axis Power Tooling



Powerful, accurate fast turret

- Powerful turret.
- Servo controlled with high speed indexing to reduce idle time and increase productivity.
- Any station can set driving tool on 12 station for flexible using.





EX-300 Series C-axis Turning Center



EX-308 Output of built-in spindle motor

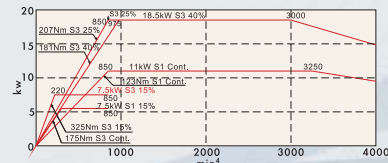

EX-310 Output of built-in spindle motor

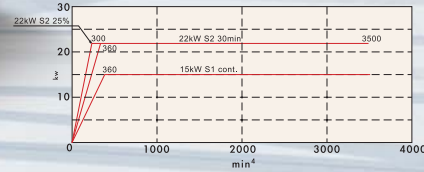

EX-500 Series Twin Spindle With C-axis Turning Center

EX-508 Output of built-in spindle motor

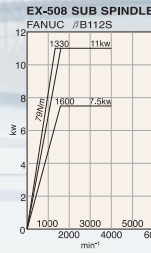
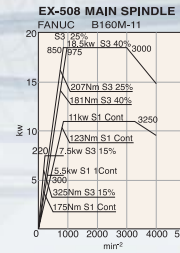

EX-510 Output of built-in spindle motor

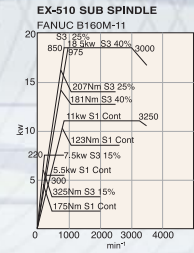
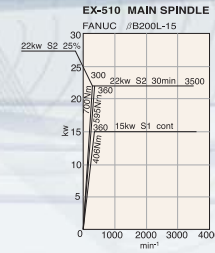

EX-700 Series Y-axis Turning Center



EX-700 Output of built-in spindle motor

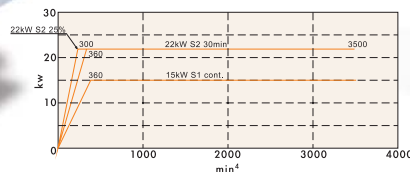

EX-900 Series Twin Spindle With Y-axis Turning Center



EX-910 Output of built-in spindle motor

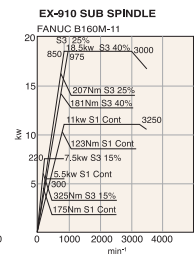
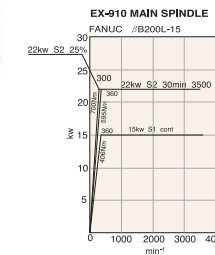



EX-300 Series

EX-500 Series

EX-308 Machine Dimension

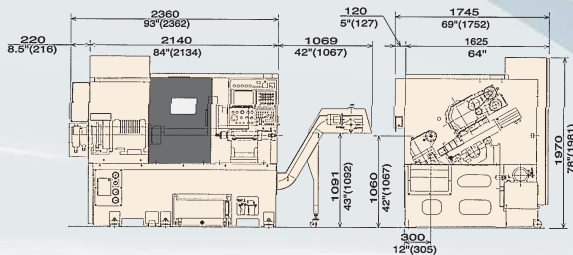

EX-508 Machine Dimension

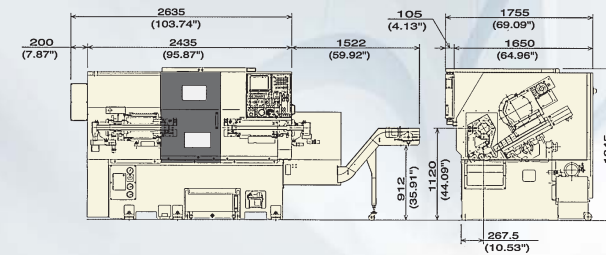

EX-310 Machine Dimension

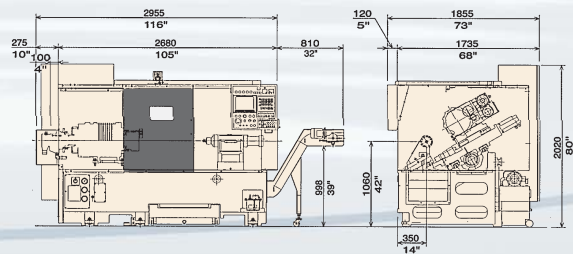

EX-510 Machine Dimension

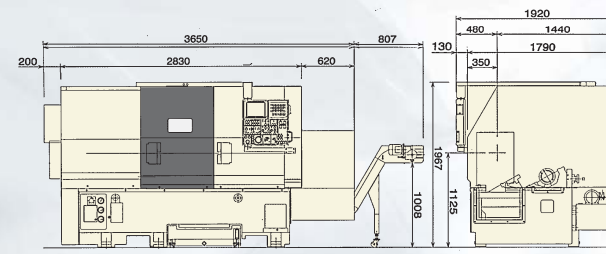

EX-700 Series

EX-900 Series

EX-710 Machine Dimension

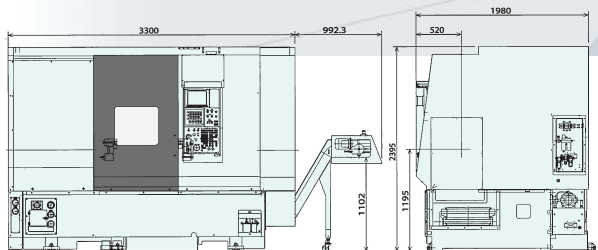

EX-910 Machine Dimension

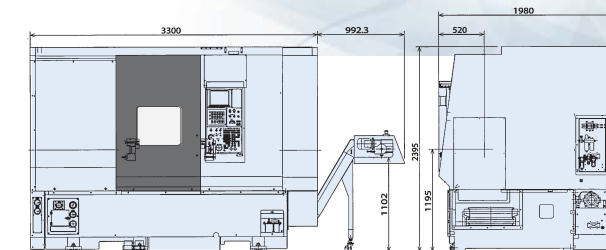

EX-710 / 910 Major Dimension of Headstock

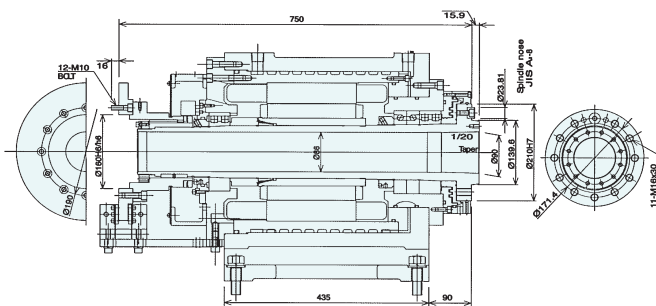

EX-910 2nd Spindle

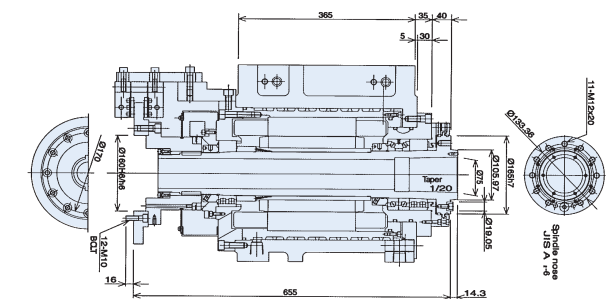

EX-300 Series

EX-308 Tool Interference and Working Range

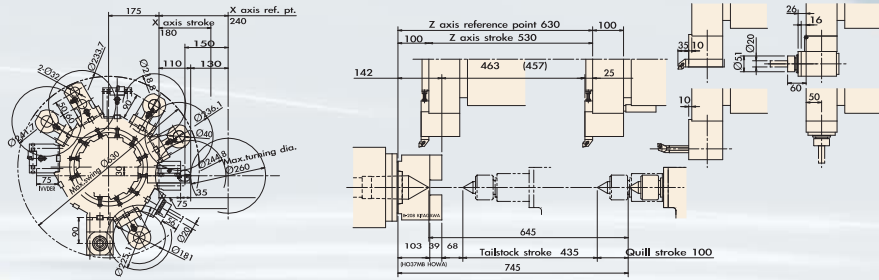

EX-310 Tool Interference and Working Range

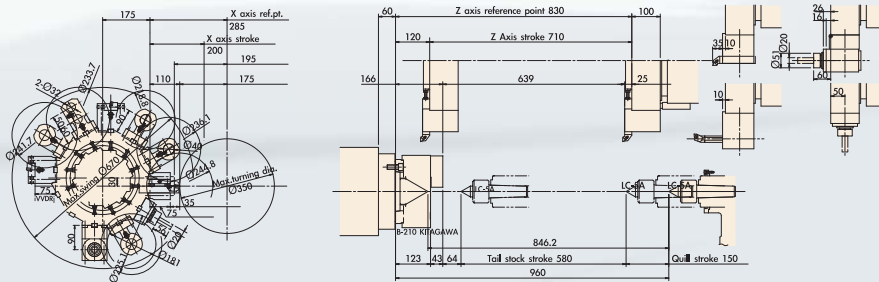

EX-700 Series

EX-710 Tool Interference and Working Range

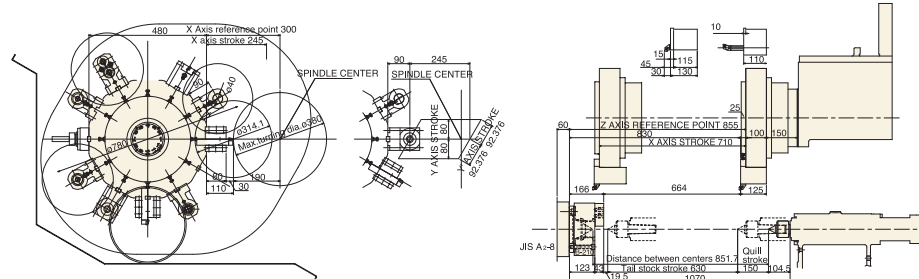

EX-500 Series

EX-508 Tool Interference and Working Range

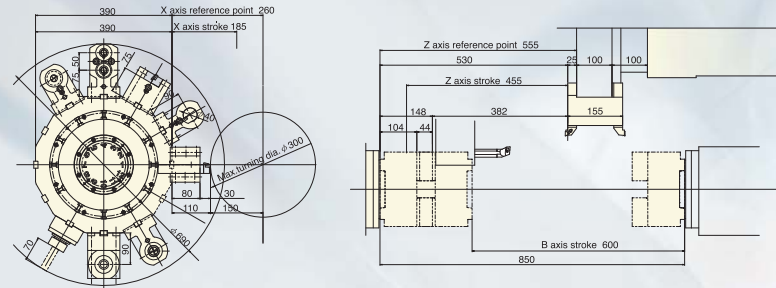

EX-510 Tool Interference and Working Range

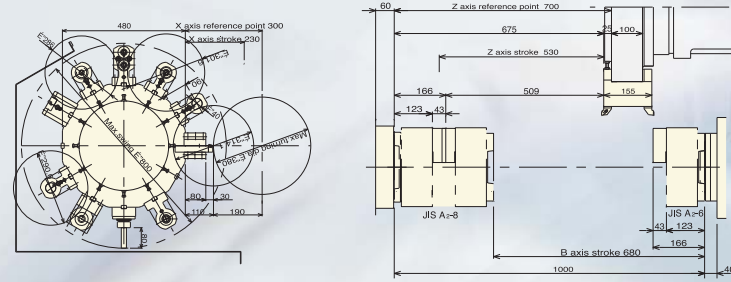

EX-900 Series

EX-910 Tool Interference and Working Range

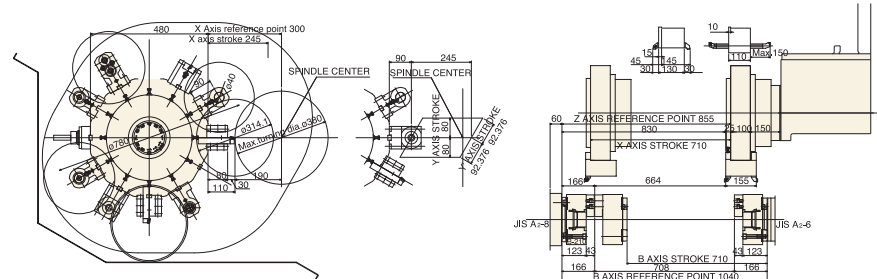



EX-308 / 310 Tooling System

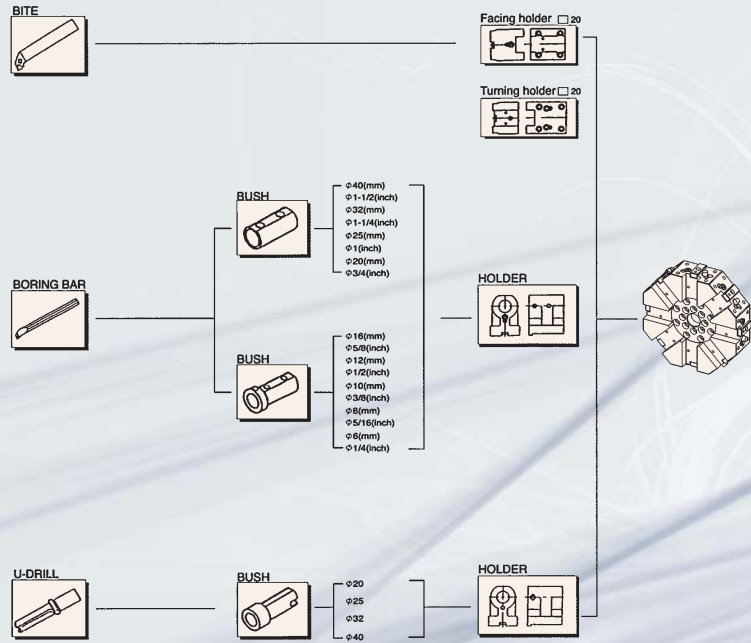

Rotary Tool Holder

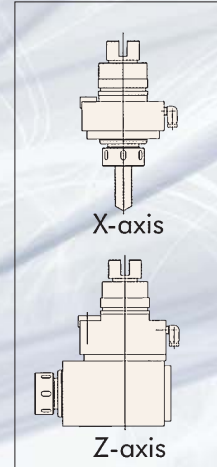

EX-508 / 510 / 700 / 900 Tooling System

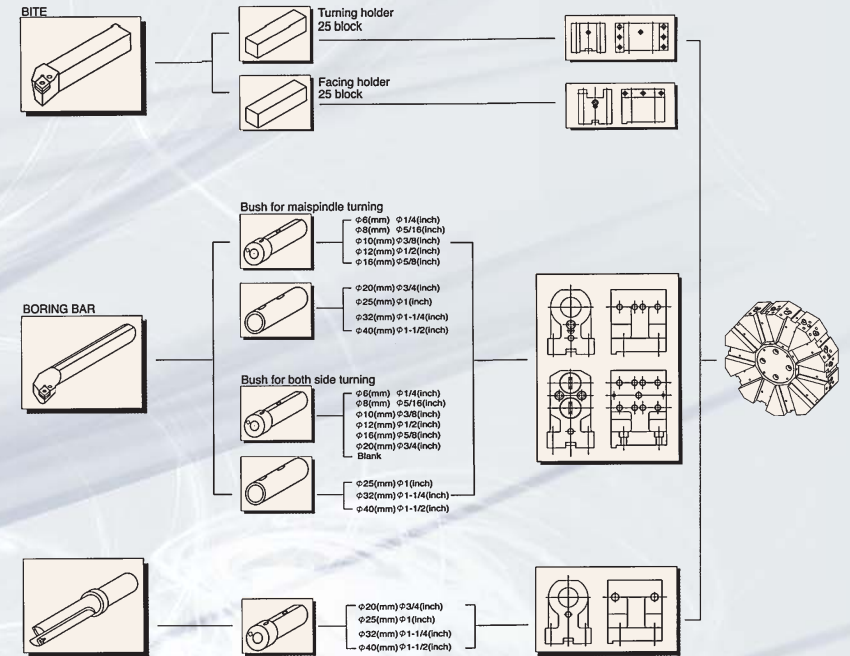



EX - 3 / 5 Series Specification

Machine Accessories

ITEMS		UNIT	EX-308	EX-310	EX-508	EX-510	Items	EX-3 Series	EX-5 Series
CAPACITY	Maximum Turning Dia	mm / inch	260(10.2")	350(13.8")	300(11.8")	380(14.9")	Fanuc controller	21i - TB	18i - TB
	Maximum Turning Length	mm / inch	530(20.9")	710(28.0")	380(15")	509(20")	Fanuc spindle motor	●	●
	Bar Work Capacity						Fanuc X & Z axis servo motor	●	●
	Left Hand Spindle	mm / inch	52(2.05")	75(2.95")/77(3.03")	52(2.05")	75(2.95")	Hydraulic clamping chuck & cylinder	●	●
	Right Hand Spindle	mm / inch	--	--	35(1.38")	52(2.05")	3-Jaw thru-hole chuck	●	●
TRAVEL	Chuck Size	inch	8"	10"	8"	10"	Hydraulic turret	●	●
	X-axis Travel	mm / inch	180(7.1")	200(7.8")	185(7.28")	230(9.05")	Boring var tool holder	●	●
	Z-axis Travel	mm / inch	530(20.9")	710(27.9")	455(18")	530(20.87")	U-drill tool holder	●	●
SPINDLE	B-axis Travel	mm / inch	--	--	600(23.62")	680(26.77")	O.D. tool holder	●	●
	Number of Spindle		1	1	2	2	Bush (Each size one set)	●	●
	Spindle Speed Range	rpm	30-4000	35-3500	4000	3500	Soft jaw	●	●
	Number of Spindle Range	JIS	1	1	2	2	Hydraulic tailstock	●	●
	Type of Spindle Nose	mm	A2-6	A2-8	A2-6	A2-8,A2-6	Programmable tailstock quill	●	●
	Through Spindle Diameter						Coolant pump	●	●
	Left Hand Spindle	mm / inch	63(2.4")	86(3.3")	63(2.48")	86(3.39")	Chuck with M function	●	●
	Right Hand Spindle	mm / inch	--	--	46(1.81")	63(2.48")	Chip conveyer interface	●	●
	Spindle Bearing inner Diameter						Cycle finish light	●	●
	Left Hand Spindle	mm / inch	100(3.94")	120(4.72")	100(3.94")	120(4.72")	Working lamp	●	●
TURRET	Right Hand Spindle	mm / inch	--	--	120(4.72")	100(3.94")	Tool box	●	●
	Number of Turret		1	1	1	1	Fanuc warranty	2 years	2 years
	Type of Turret	STATION	12	12	12	12	Mechanical parts warranty	1 year	1 year
	Size of Tool	mm / inch	25(1")x25(1")	25(1")x25(1")	25(1")x25(1")	25(1")x25(1")	Hard Jaw	□	□
	Size of Coupling	mm / inch	210(8.27")	250(9.84")	210(8.27")	250(9.84")	Tool setter	□	□
FEED	Rapid Traverse X-axis	m / min	20	16	20	16	Chip conveyer	□	□
	Rapid Traverse Z-axis	m / min	24	20	24	20	Rigid tapping	●	●
	Jog Feed Rate X-axis	mm / rev	0-1260	0-1260	0-1260	0-1260	Variable lead threading	□	□
	Jog Feed Rate Z-axis	mm / rev	0-1260	0-1260	0-1260	0-1260	Multiple repetitive cycle G70~G76	□	□
	Spindle Drive Motor						Graphic function	□	□
MOTOR	Left Hand Spindle	kw	11/18.5	15/22	11/18.5	15/22	Spindle orientation	●	●
	Right Hand Spindle	kw	--	--	7.5/11	11/18.5	CE & EMC regulation	□	□
	Feed Motor X-axis	kw	1.2	1.2	1.2	1.2	Manual guide i with color screen	□	□
	Feed Motor Z-axis	kw	2.5	2.5	3.0	3.0	Part program storage length 160 m.	□	□
	Hydraulic Pump Motor	kw	1.5	1.5	1.5	1.5	Part program storage length 320 m.	□	□
	Lubricant Pump Motor	w	4	4	4	4	Number of registerable programs 120 pcs.	□	□
	Coolant Pump Motor	w	400	400	400	400	Number of registerable programs 200 pcs.	□	□
	CNC Controller		FANUC 21iTB	FANUC 21iTB	FANUC 18iTB	FANUC 18iTB			
	Live Tool	kw	5.5	5.5	5.5	5.5			
TANK	Hydraulic Oil Tank	L	40	40	40	40			
	Lubricant Tank Capacity	L	2	2	2	2			
	Coolant Tank Capacity	L	200	230	200	220			
SIZE	Length	mm / inch	2360(93.0")	2890(113.7")	3400(133.8")	3750(147.6")			
	Height	mm / inch	1970(77.6")	2020(79.5")	1850(72.8")	2000(78.7")			
	Width	mm / inch	1745(68.7")	1855(73.0")	1900(74.8")	2000(78.7")			
	Weight	kg	4300	5600	5200	5500			

● Standard □ Optional



EX - 7 / 9 Series Specification

Machine Accessories

ITEMS	UNIT	EX-910			
		EX-710	Main Spindle	SUB-Spindle	
CAPACITY	Swing over bed	mm	600	600	600
	Max. turning diameter	mm	340	340	340
	Max. turning length	mm	660	660	660
	Max. Swing(on front door)	mm	815	815	815
	Bar Capacity	mm	75	75	52
SPINDLE	Number of head stock		1	2	2
	Spindle speeds	rpm	3500	3500	3500
	Number of spindle speed range		1	1	1
	Min. Spindle indexing angles		0.001	0.001	0.001
	Spindle nose		A-8	A2-8	A2-6
	Through hole diameter	mm	86	86	63
	Spindle bearing inner diameter	mm	120	120	100
HEADSTOCK	Number of head stock		1	2	2
	Travel of head stock (B axis)	mm	--	--	710
	Rapid traverse (B axis)	mm/min	--	--	20000
	Feed rate	mm/min	--	--	20000
	Jog feed rate	mm/min	--	--	0-1260
TOOL SLIDE	Number of turret		1	1	1
	Type of tool slide		12 station drum type	12 station drum type	12 station drum type
	Travel of tool slide X axis	mm	245	245	245
	Travel of tool slide Y axis	mm	160 (80+80)	160 (80+80)	160 (80+80)
	Travel of tool slide Z axis	mm	710	710	710
	Rapid traverse X/Y axis	mm/min	16000	16000	16000
	Rapid traverse Z axis	mm/min	200000	200000	200000
	Jog feed rate	mm/min	0-1260	0-1260	0-1260
	Number of tools on turret		12	12	12
	Square shank height	mm	25	25	25
	Shank diameter of boring bar	mm	40	40	40
	Indexing time	sec.	0.35	0.35	0.35
ROTARY TOOL	Number of rotary tools		Max. 12	Max. 12	Max. 12
	Rotational speed	rpm	4000	4000	4000
	Max. Diameter of tool shank	mm	20	20	20
	Tool spindle bearing inner diameter	mm	35	35	35
MOTOR	Main spindle motor	kw	22	22	18.5
	Rotary tool spindle motor	kw	5.5	5.5	5.5
	Feed motor B axis B	kw	--	--	3.0
	Feed motor X axis X	kw	1.8	1.8	1.8
	Feed motor Y axis Y	kw	1.2	1.2	1.2
	Feed motor Z axis Z	kw	3.0	3.0	3.0
	Turret indexing motor	kw	1.2	1.2	1.2
	Hydraulic pump motor	kw	1.5	1.5	1.5
	Lubricant pump motor	kw	0.004	0.004	0.004
	Coolant pump moto	kw	0.4	0.4	0.4
POWER SOURCES	Required electric power	KVA	50	50	50
	Required electric voltage	V	200/220/230/380/415/440/460+10%		
	Required electric frequency	Hz	50/60	50/60	50/60
	Compressed air pressurs	Mpa	0.5	0.5	0.5
	Compressed air flow rate	L/min	10	10	10
TANK CAPACITY	Hydraulic oil tank	L	40	40	40
	Lubricant tank	L	2	2	2
	Coolant tank	L	200	200	200
	Oil controller unit	L	200	200	200
DIMENSION	Height of machine	mm	2300	2300	2300
	Height from floor to spindle center	mm	1200	1200	1200
	Floor space	mm_mm	3250 x 1840	3250 x 1840	3250 x 1840
	Mass of machine	kg	6400	6500	6500

Items	EX-7 Series	EX-9 Series
Fanuc controller	●	●
Fanuc spindle motor	●	●
Fanuc X & Z axis servo motor	●	●
Hydraulic clamping chuck & cylinder	●	●
3-Jaw thru-hole chuck	●	●
Hydraulic turret	●	●
Boring var tool holder	●	●
U-drill tool holder	●	●
O.D. tool holder	●	●
Bush (Each size one set)	●	●
Soft jaw	●	●
Hydraulic tailstock	●	●
Programmable tailstock quill	●	●
Coolant pump	●	●
Chuck with M function	●	●
Chip conveyor interface	●	●
Cycle finish light	●	●
Working lamp	●	●
Tool box	●	●
Fanuc warranty	2 years	2 years
Mechanical parts warranty	1 year	1 year
Hard Jaw	□	□
Tool setter	□	□
Chip conveyor	□	□
Rigid tapping	●	●
Variable lead threading	□	□
Multiple repetitive cycle G70~G76	□	□
Graphic function	□	□
Spindle orientation	●	●
CE & EMC regulation	□	□
Manual guide i with color screen	□	□
Part program storage length 160 m.	●	●
Part program storage length 320 m.	□	□
Number of registerable programs 120 pcs.	□	□
Number of registerable programs 200 pcs.	□	□

● **Standard** □ **Optional**